

# A46JE/A46JRT

## ARTICULATED BOOM LIFTS



- Class-leading articulated boom lifts
- Choose from electric or rough terrain diesel models
- Highly manoeuvrable with tight turning radius
- Superb working envelope with zero tailswing
- Robust, reliable and easy to operate

 **snorkel**  
[www.snorkellifts.com](http://www.snorkellifts.com)

# ARTICULATED BOOM LIFTS

# A46JE/A46JRT

DIMENSIONS	A46JE	A46JRT
Max. working height	16.0m	16.3m
Max. platform height	14.0m	14.3m
Max. working outreach	7.6m	7.6m
Clearance height at max. outreach	7.46m	7.67m
Platform size	1.0m x 1.83m	1.0m x 1.83m
Chassis width (A)	1.7m	2.1m
Overall length (B)	5.6m	5.6m
Stowed height (C)	2.0m	2.16m
Ground clearance	152mm	330mm

PERFORMANCE		
Platform capacity (SWL)	227kg	227kg
Max. drive height	14.0m	14.3m
Max. wind speed	12.5m/s	12.5m/s
Max. drive speed (stowed)	5.1km/h	6.4km/h
Max. drive speed (elevated)	0.8km/h	1.3km/h
Jib length	1.5m	1.5m
Jib arc	140°	140°
Platform rotation	160°	160°
Turret rotation (non-continuous)	360°	360°
Tailswing	0m	0m
Raise/lower time	99/92 seconds	101/98 seconds
Gradeability	30%	40%
Inside turning radius	0.53m	0.78m
Outside turning radius	3.0m	3.55m
Tyres	Non-marking IN240/55D 17.5	High grip, foam-filled 355/55D625NHS 17.5
Controls	proportional	proportional
Drive system	2 wheel drive	4 wheel drive

POWER		
Power source	8 x 6V 360Ah batteries	Kubota V1505T 24.9hp Diesel

WEIGHT		
Weight	6,850kg	7,555 kg

## WORKING ENVELOPE

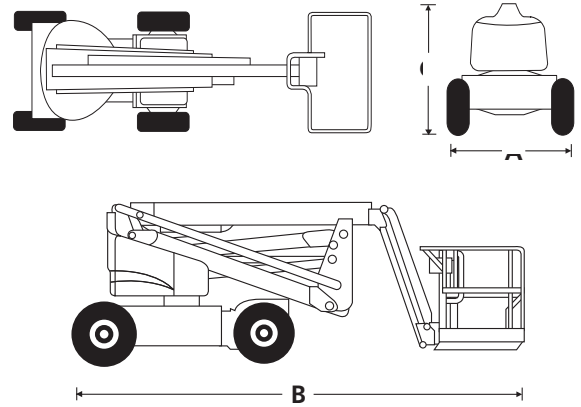
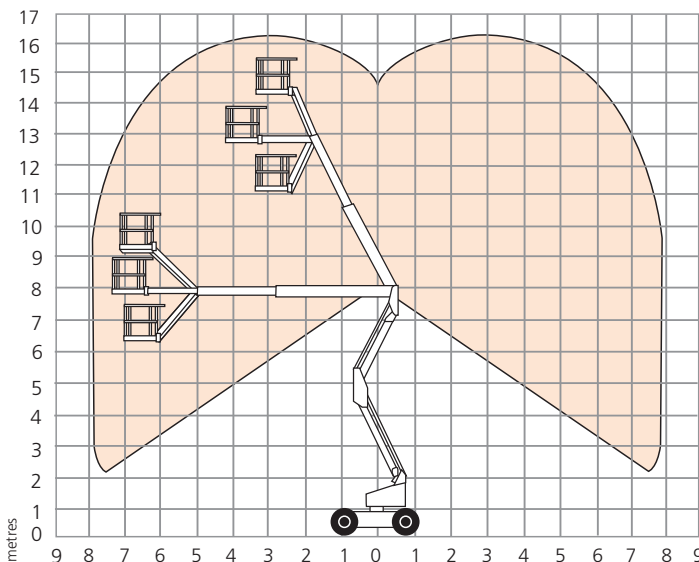

## STANDARD FEATURES

- Snorkel Guard™ secondary guarding system
- Multi-function proportional controls
- Oscillating front axle (A46JRT)
- Power line to platform
- Zero tailswing
- Hour meter & on-board diagnostics display
- Foam filled tyres (A46JRT)
- Non-marking tyres (A46JE)
- Battery charge indicator (A46JE)
- 2 year parts & labour, 5 year structural warranty
- CE approved

## OPTIONS

- Special paint colours
- AC generator 110V/240V 2kW (A46JRT)
- Airline to platform (A46JRT)
- Non-marking tyres (A46JRT)
- Environmental hydraulic oil
- 1.52m aluminium platform with Snorkel Guard™
- Aircraft package
- Deluxe aircraft package
- Cold weather package (A46JRT)
- Extreme cold weather package (A46JRT)
- Light package (A46JRT)
- Dual fuel

**snorkel**

Vigo Centre, Birtley Road,  
Washington, Tyne & Wear,  
NE38 9DA, U.K.

t: +44 (0) 845 1550 057

e: sales@snorkellifts.com

www.snorkellifts.com