

# TL39

## TOWABLE BOOM LIFT



- Tough yet compact trailer mounted boom lift
- Easy to set-up hydraulic outriggers
- Manoeuvrable articulating/telescopic boom
- Smooth, easy to operate controls
- Simple to maintain

 **snorkel**  
[www.snorkellifts.com](http://www.snorkellifts.com)

# TOWABLE BOOM LIFT

# TL39

DIMENSIONS	TL39
Max. working height	13.5m
Max. platform height	11.5m
Max. working outreach	6.4m
Platform width (C)	1.12m
Platform depth (D)	0.7m
Outrigger footprint (A x B)	4.0m x 3.6m
Towing width (E)	1.61m
Towing length (F)	4.7m
Stowed height (G)	2.01m

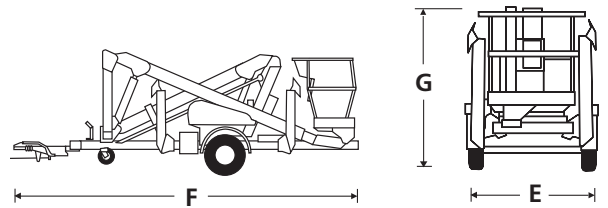
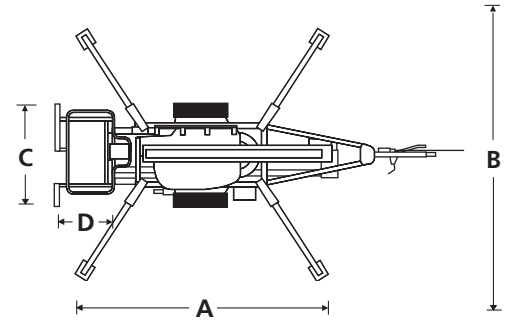

PERFORMANCE	
Platform capacity (SWL)	215kg
Max. wind speed	12.5m/s
Turret rotation (non-continuous)	540°
Tyres	185R14C
Controls	electric over hydraulic, variable speed

POWER	
Power source	24V battery (4 x 6V 226Ah batteries)
Power options	bi-energy, gasoline or diesel engine, or 230V mains

WEIGHT	
Weight (battery model)	1,480kg

## STANDARD FEATURES

- Articulating / telescopic boom configuration
- Hydraulic outriggers
- Electric controls at platform
- Power line to platform
- Integral road lighting board
- Integrated automatic battery charger 110V-230V
- 2 year parts & labour, 5 year structural warranty
- CE approved

## OPTIONS

- Special paint colours
- Auto-level outriggers with LED indicators
- Work lights in platform
- Airline to platform
- Flashing amber light
- Nylon spreader pads (set of 4)
- Environmental hydraulic oil

## WORKING ENVELOPE

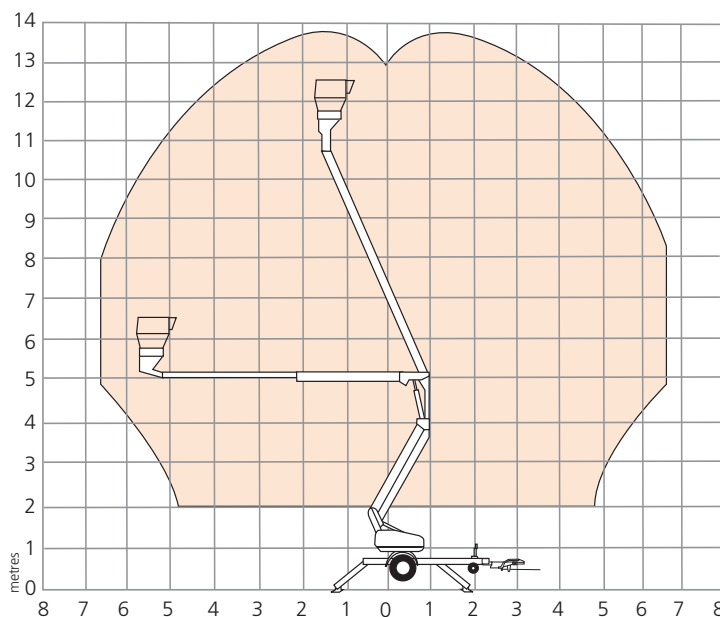

**snorkel** [www.snorkellifts.com](http://www.snorkellifts.com)

Vigo Centre, Birtley Road,  
Washington, Tyne & Wear,  
NE38 9DA, U.K.

t: +44 (0) 845 1550 057

e: sales@snorkellifts.com