

# ML12/ML16/ML20M

## MATERIAL LIFTS



- A high specification material lift, with best-in-class load capacity
- Narrow design with ultra compact reduced height mast to easily pass through a single doorway
- Robust and reliable, built to handle the demands of the rental industry
- Features a dual handle, shift-on-the-fly, two-speed winch for improved productivity

 **snorkel**  
[www.snorkellifts.com](http://www.snorkellifts.com)

# MATERIAL LIFTS

# ML12/ML16/ML20M

DIMENSIONS	ML12M	ML16M	ML20M
Lift height – forks up	3.8m	4.9m	6.0m
Lift height – forks down	3.3m	4.4m	5.5m
Stowed width <b>(A)</b>	0.77m	0.77m	0.77m
Stabiliser width <b>(B)</b>	1.63m	1.63m	1.63m
Stowed length	0.84m	0.88m	0.91m
Operating length <b>(C)</b>	1.72m	1.85m	2.10m
Stowed height <b>(D)</b>	1.59m	1.59m	1.59m
Fork width (outside)	0.58m	0.58m	0.58m
Fork length <b>(E)</b>	0.76m	0.76m	0.76m
Ground clearance	60mm	60mm	60mm

PERFORMANCE			
Max. load capacity (0.36m load centre)	318kg	295kg	272kg
Max. load capacity (0.61m load centre)	200kg	195kg	181kg
Max. load capacity (1.07m load centre)	84kg	79kg	80kg
Min. load height	150mm	150mm	150mm
Winch (high speed)		13.1 cranks/m	
Winch (low speed)		49.2 cranks/m	

WEIGHT			
Weight	120 lbs	135 lbs	150 lbs

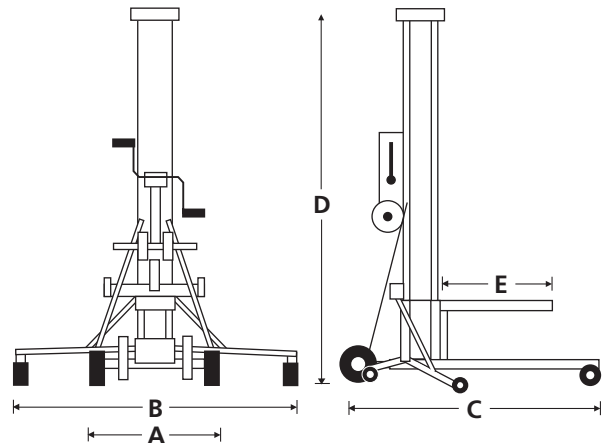

## STANDARD FEATURES

- Stabilisers with non-marking swivel casters (ML12M)
- Non-marking transport/loading wheels
- Cable guard
- Mast brake
- Dual handle, two-speed shift-on-the-fly winch
- Metal cable pulleys with sealed bearings
- Heavy-gage aluminium extrusions
- Heavy-duty, non-marking casters
- Quick-fold stabilisers
- Crane attachment point
- 2 year parts & labour, 5 year structural warranty
- CE Approved

## OPTIONS

- Adjustable forks
- Boom
- Pipe cradle
- Fork extensions
- Load platform
- Stabilisers with non-marking swivel casters
- Special paint colours

## LOAD CAPACITY - STANDARD FORKS

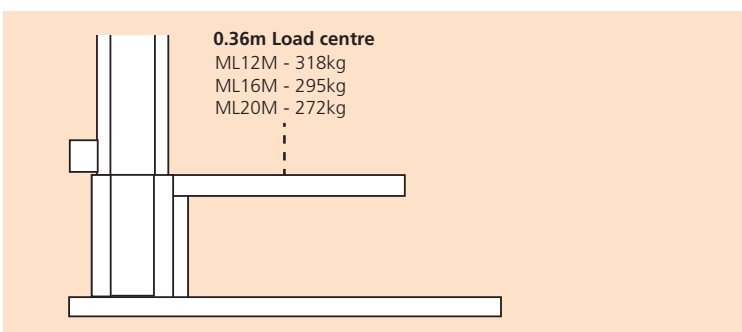

## LOAD CAPACITY - EXTENDED FORKS

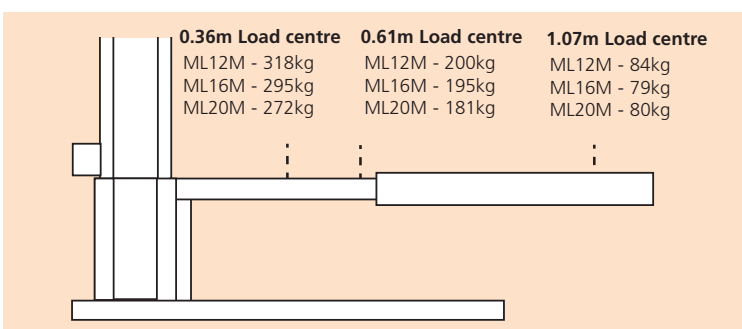

**snorkel** [www.snorkellifts.com](http://www.snorkellifts.com)

Vigo Centre, Birtley Road,  
 Washington, Tyne & Wear,  
 NE38 9DA, U.K.

t: +44 (0) 845 1550 057  
 e: sales@snorkellifts.com