

TB80/TB86J

TELESCOPIC BOOM LIFTS



- Robust diesel telescopic boom lifts
- Available with and without a jib boom
- Powerful 4 wheel drive and 4 wheel steer
- Excellent rough terrain performance
- Designed for construction applications

 **snorkel**
www.snorkellifts.com

TELESCOPIC BOOM LIFTS

TB80/TB86J

DIMENSIONS	TB80	TB86J
Max. working height	26.4m	28.2m
Max. platform height	24.4m	26.2m
Max. working outreach	21.7m	23.9m
Platform size	0.91m x 2.44m	0.91m x 2.44m
Overall width (A)	2.6m	2.6m
Overall length (B)	11.8m	12.9m
Stowed height (C)	2.9m	2.9m
Ground clearance	330mm	330mm

PERFORMANCE		
Platform capacity (SWL)	227kg	227kg
Max. drive height	24.4m	26.2m
Max. wind speed	12.5m/s	12.5m/s
Max. drive speed (stowed)	4.6km/h	4.6km/h
Max. drive speed (elevated)	1.0km/h	1.0km/h
Jib length	n/a	2.0m
Jib arc	n/a	135° (+70°/-65°)
Platform rotation	157°	150°
Turret rotation (continuous)	360°	360°
Tailswing	2.02m	2.02m
Raise/lower time	195/175 sec	230/210 sec
Gradeability	40%	40%
Inside turning radius	2.4m	2.4m
Outside turning radius	4.7m	4.7m
Tyres	15 x 625 foam filled lug	
Controls	proportional joystick	
Drive system	4 wheel drive	

POWER	
Power source	Kubota V2403 59 hp diesel - Tier 4 Final

WEIGHT		
Weight	16,556kg	18,655kg

WORKING ENVELOPE

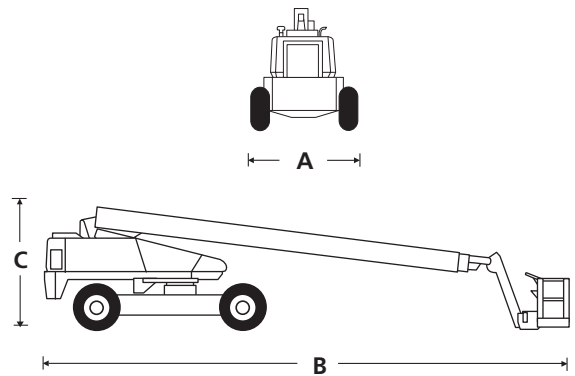
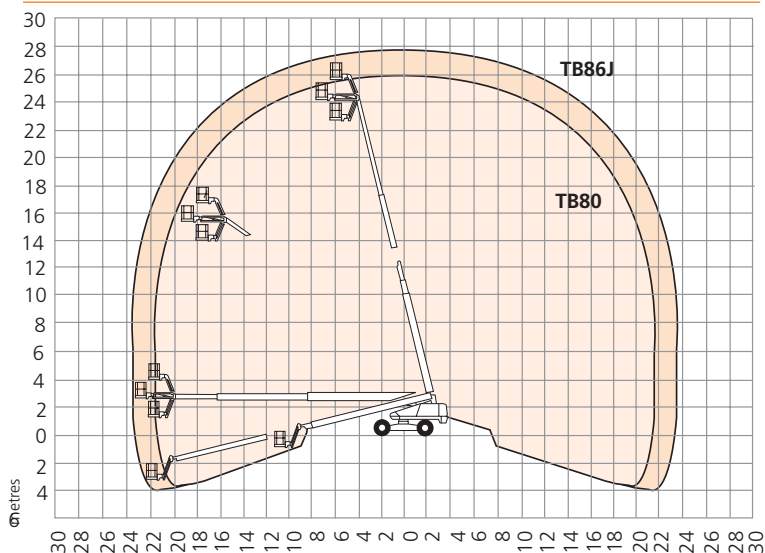

STANDARD FEATURES

- Snorkel Guard™ secondary guarding system
- 4 wheel drive, steer & crab steer
- Hydraulic platform rotation
- 360° continuous turntable rotation
- Drive motion alarm
- Flashing amber light
- Foam filled lug tyres
- Proportional drive, boom lift, swing & extend
- Rheostat control for jib & platform level
- Power line to platform
- Tri-entry platform
- Dual lanyard attachment points
- Horn
- Hour meter & on-board diagnostics display
- 3.5° tilt alarm
- 2 year parts & labour, 5 year structural warranty
- CE approved

OPTIONS

- Special paint colours
- Airline to platform
- Non-marking tyres
- AC generator 110V/240V 2kW
- Cold weather package
- Extreme cold weather package
- Extreme environment package
- Light package
- Tow kit
- Glazier package
- 12k Generator package
- 12k Generator/Welder package
- Environmental hydraulic oil
- Tool tray

snorkel www.snorkellifts.com

Vigo Centre, Birtley Road,
Washington, Tyne & Wear,
NE38 9DA, U.K.

t: +44 (0) 845 1550 057
e: sales@snorkellifts.com