

SA11

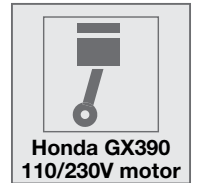
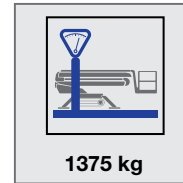
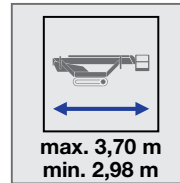
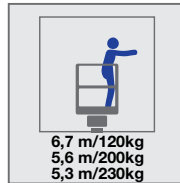
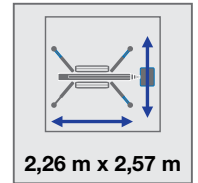
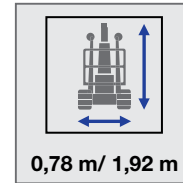
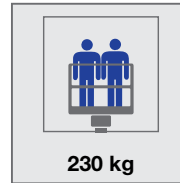
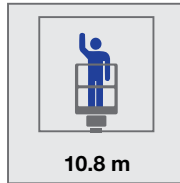

SA11

SOLD & SERVICED
IN THE UK & IRELAND BY

snorkelTM

UK

Vigo Centre, Birtley Road, Washington,
Tyne & Wear, NE38 9DA, U.K.
T: +44 (0)845 1400 758
E: sales@snorkellifts.co.uk
www.snorkellifts.co.uk

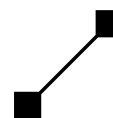

RUTHMANN
professionals at work

RUTHMANN Italia S.r.l.
Via Santa Maria del Piano di Sotto 91
47854 Montescudo (RN) - ITALY
Phone. +39 0541 756872 - Fax +39 0541 729800
info@ruthmann.it - www.ruthmann.it
info@bluelift.it - www.bluelift.it

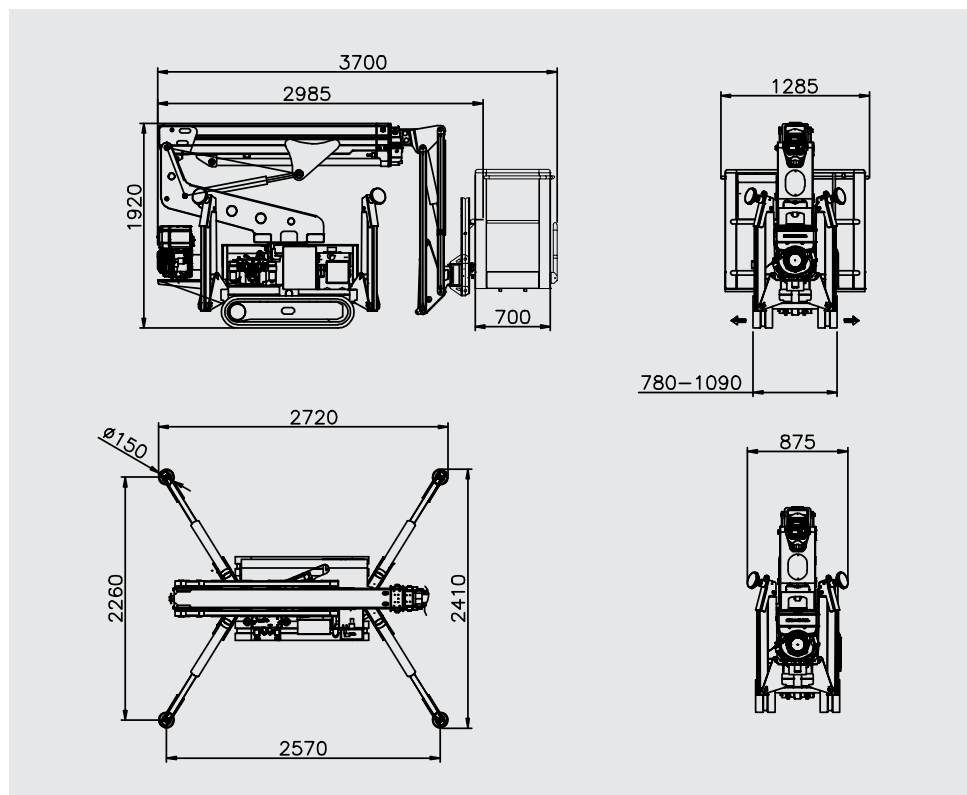
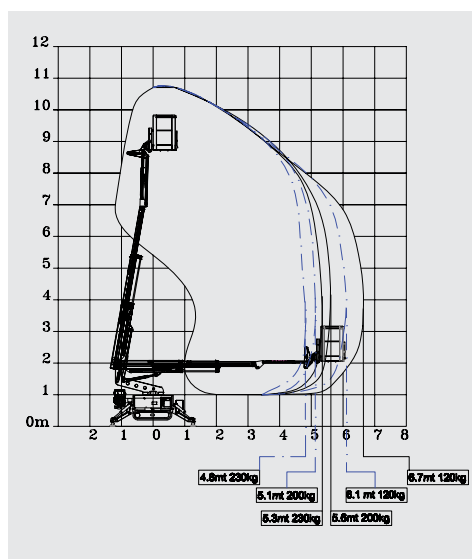
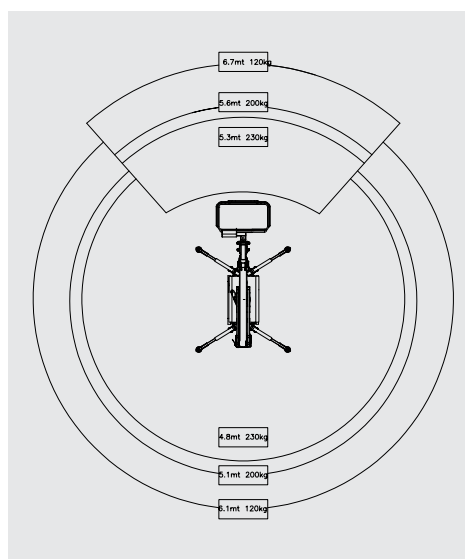

Equipment standard

- Quickly removable aluminum basket
- i-Performing electric pump (patented) with auto Start/Stop system
- 110 or 230V power outlet in basket
- Cable remote control with interactive and multi-lingual display
- Moment limiting device
- Automatic center position of turret
- Proportional and simultaneous electro-hydraulic controls
- Proportional track drive with hydraulic breaking system
- Driving Lateral slope alarm with safety stop
- Driving possible with jib boom raised (with selector)
- Interlock outriggers/booms
- Emergency push-button with engine stop
- Simple Emergency lowering procedure
- Hand pump for the emergency lowering of platform
- Covers on outrigger cylinder's piston rod, oil tank and emergency controls
- Modem connection plug for diagnosis/software upgrading in remote
- Powered according to EN280 norm and international safety regulation

Optional

- Basket rotation*
- Radio remote control
- Self Stabilizing System
- Air/Water tube
- Petrol engine HONDA iGX with automatic RPM control and Automatic START & STOP
- Diesel engine HATZ 1B40 with automatic RPM control and Automatic START & STOP
- 110V power
- No-marking crawlers
- Track width adjusting system*
- Double drive speed system with safety control
- BlueLithium option
- Go-Home function
- Custom paint work

*This option increase the overall weight of platform

Subject to change without notice

SA11

Working height, max.	10.8 m
Horizontal outreach, max.	6.7 m/120 kg 5.6 m/200 kg 5.3 m/230kg
Basket capacity	230 kg
Basket dimension	1.3 m x 0.7 m x 1.1 m
Turret rotation	340°
Overall weight	1375 kg
Travel speed	1,5 km/h
Gradeability, max.	28%
Combustion engine	Honda GX390
Electric motor	230V - 2,2 kW