

# BLUELIFT

[www.ruthmann.it](http://www.ruthmann.it)  
[www.bluelift.it](http://www.bluelift.it)

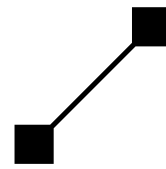

**RUTHMANN**  
professionals at work

# C12/6.5H

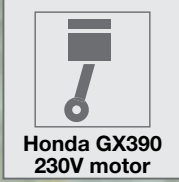
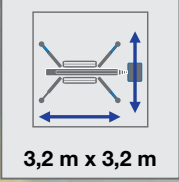
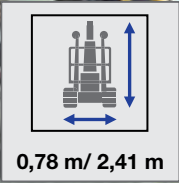
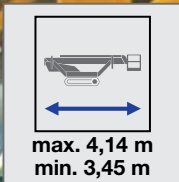
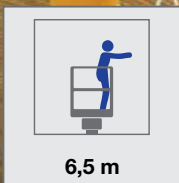

# C12/6.5H

SOLD & SERVICED  
IN THE UK & IRELAND BY

## snorkel UK

Vigo Centre, Birtley Road, Washington,  
Tyne & Wear, NE38 9DA, U.K.  
T: +44 (0)845 1400 758  
E: sales@snorkellifts.co.uk  
[www.snorkellifts.co.uk](http://www.snorkellifts.co.uk)

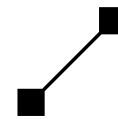

**RUTHMANN**  
professionals at work

RUTHMANN Italia S.r.l.  
Via Santa Maria del Piano di Sotto 91  
47854 Montescudo (RN) - ITALY  
Phone. +39 0541 756872 - Fax +39 0541 729800  
info@ruthmann.it - www.ruthmann.it  
info@bluelift.it - www.bluelift.it

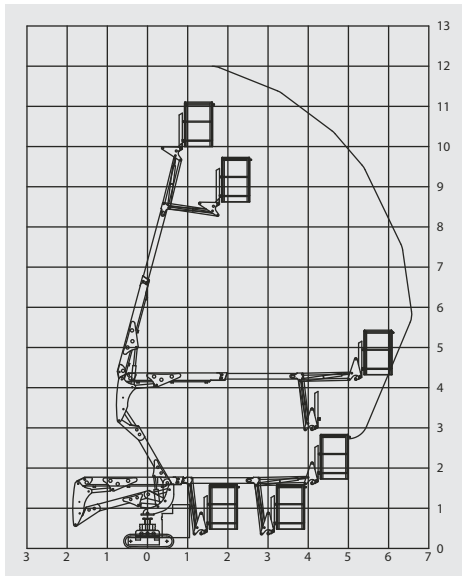

### Equipment standard

- Quickly removable aluminum basket
- i-Performing electric pump (patented) with auto Start/Stop system
- 230V power outlet in basket
- Cable remote control with interactive and multi-lingual display
- Load limiting device
- Automatic center position of turret
- Proportional and simultaneous electro-hydraulic controls
- Proportional track drive with hydraulic breaking system
- Driving Lateral slope alarm with safety stop
- Driving possible with jib boom raised (with selector)
- Interblock outriggers/booms
- Emergency push-button with engine stop
- Simple Emergency lowering procedure
- Hand pump for the emergency lowering of platform
- Covers on outrigger cylinder's piston rod, oil tank and emergency controls
- Modem connection plug for diagnosis/software upgrading in remote
- Produced according to EN280 norm and international safety regulation

### Optional

- Basket rotation\* (on C12H-HB-outreach reduce to 6 m)
- Radio remote control
- Self Stabilizing System
- Air/Water tube
- Petrol engine HONDA iGX with automatic RPM control and Automatic START & STOP
- Diesel engine HATZ 1B40 with automatic RPM control and Automatic START & STOP
- 110V power
- Blue Lithium pack\*
- No-marking crawlers
- Double drive speed system with safety control
- Go-Home function
- Custom paint work

\*This option increase the overall weight of platform

**Subject to change without notice**

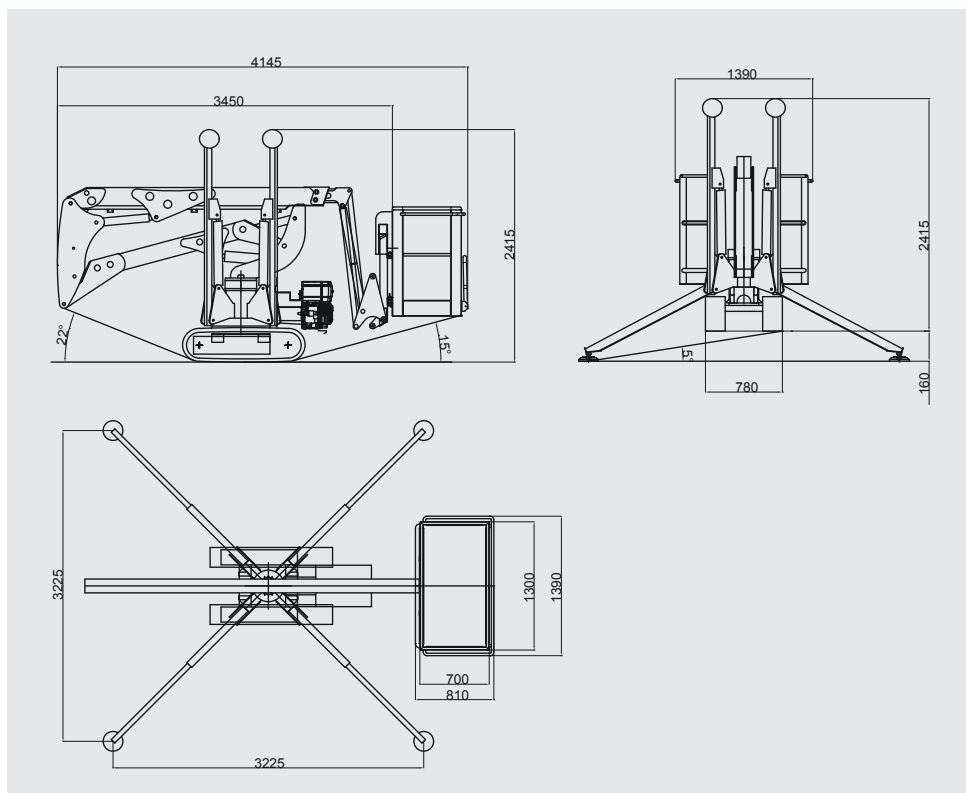

### C12/6.5H

Working height, max.	12 m
Horizontal outreach, max	6,5 m/200 kg
Basket capacity	200 kg
Basket dimension	1,3m x 0,7m x 1,1m
Turret rotation	340°
Overall weight	1550 kg
Travel speed	1,5 km/h
Gradeability, max.	28%
Combustion engine	Honda GX390
Electric motor	230V - 2,2 kW