

# AB60J

## ARTICULATED BOOM LIFT



- Tough & reliable diesel articulated boom lift
- Powerful 4 wheel drive for rough terrain
- Robust, rental tough design
- Simple to operate and maintain
- Ideal for both maintenance and construction applications

  
[www.snorkellifts.com](http://www.snorkellifts.com)

# ARTICULATED BOOM LIFT

# AB60J

DIMENSIONS	AB60J
Max. working height	20.3m
Max. platform height	18.3m
Max. working outreach	13.1m
Clearance height at max. outreach	5.94m
Platform size	2.44m x 0.91m
Overall width (A)	2.4m
Overall length (B)	8.87m
Stowed height (C)	2.51m
Ground clearance	300mm

PERFORMANCE	
Platform capacity (SWL)	227kg
Max. drive height	18.3m
Max. wind speed	12.5m/s
Max. drive speed (stowed)	5.1 km/h
Max. drive speed (elevated)	0.96 km/h
Jib length	1.8m
Jib arc	75°
Platform rotation	180°
Turret rotation (continuous)	360°
Tailswing (riser boom elevated)	0m
Tailswing (riser boom stowed)	1.52m
Raise/lower time	125/121 sec
Gradeability	30%
Inside turning radius	4.0m
Outside turning radius	6.17m
Tyres	15 x 19.5 foam filled lug
Controls	proportional joystick drive, lift & rotation
Drive system	4 wheel drive

POWER	
Power source	Kubota V2403 59 hp diesel - Tier 4 Final

## WORKING ENVELOPE

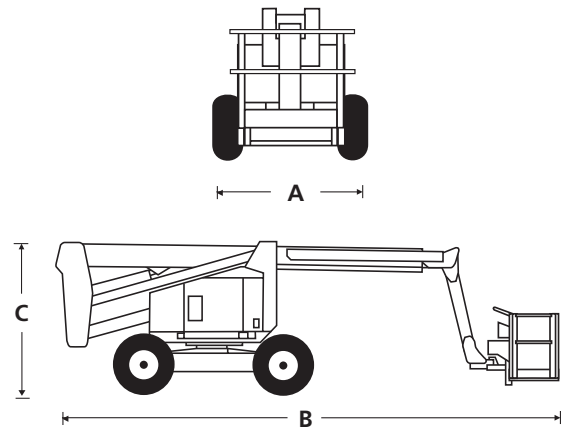
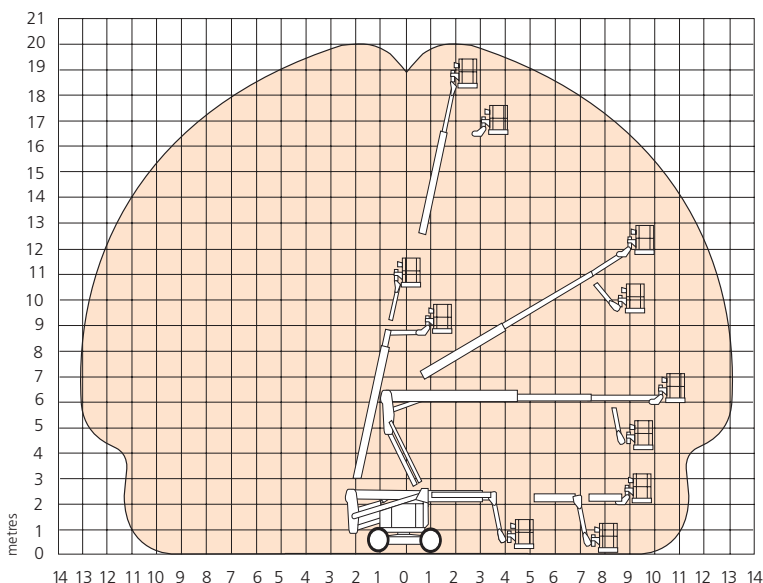

## STANDARD FEATURES

- Snorkel Guard™ secondary guarding system
- Hydraulic platform rotation
- 4 wheel drive
- Drive motion alarm
- Power line to platform
- Flashing amber light
- Proportional drive, lift and swing
- Dual lanyard attachment points
- Foam filled lug tyres
- Horn
- 3.5° tilt alarm
- 2 year parts & labour, 5 year structural warranty
- CE approved

## OPTIONS

- Special paint colours
- AC generator 110V/240V 2kW
- Non marking tyres
- Airline to platform
- Aircraft package
- Deluxe aircraft package
- Cold weather package
- Extreme cold weather package
- Extreme environment package
- Light package
- Tow kit
- Glazier package
- Tool tray
- Environmental hydraulic oil



Vigo Centre, Birtley Road,  
Washington, Tyne & Wear,  
NE38 9DA, U.K.

t: +44 (0) 845 1550 057

e: sales@snorkellifts.com

www.snorkellifts.com