

# SR626

## COMPACT ROUGH TERRAIN TELEHANDLER



- Full-time 4 wheel drive
- Fully enclosed cab
- Power assisted steering
- Proportional joystick controls
- Simple to operate & maintain

 **snorkel**  
[www.snorkellifts.com](http://www.snorkellifts.com)

# COMPACT ROUGH TERRAIN TELEHANDLER

# SR626

## CAPABILITIES SR626

Max. lift capacity	2,600kg
Max. lift height (A)	5.79m
Max. forward reach	3.2m

## DIMENSIONS

Overall width (B)	1.89m
Stowed height (C)	1.93m
Length to fork face (D)	4.19m
Wheelbase	2.5m
Ground clearance	220mm

## PERFORMANCE

Max. drive speed	27km/h
Raise/lower time	6.9/5 sec
Frame levelling	n/a
Hydraulic flow (per minute)	70L
Hydraulic pressure	230bar
Hydraulic oil capacity	70L
Fuel capacity	80L
Outside turning radius	3.25m
Tyres	12 x 16.5

## POWER

Power source	Yanmar 51.7kW - Tier 4 Final diesel
--------------	-------------------------------------

## WEIGHT

Weight	4,700kg
--------	---------

## LOAD CHART

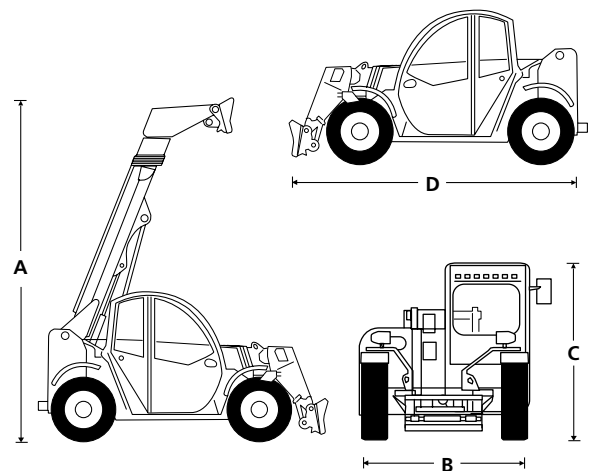
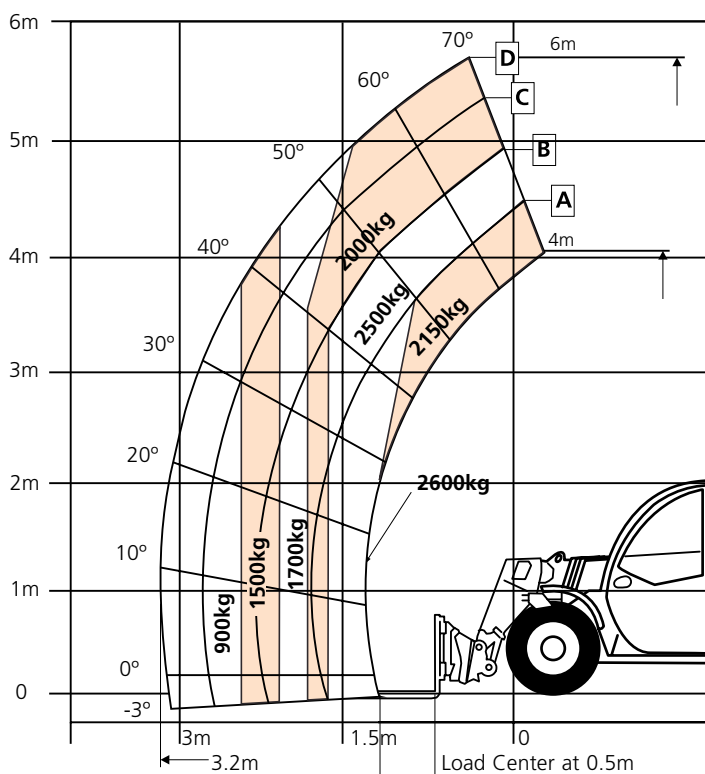

## STANDARD FEATURES

- Full time 4 wheel drive
- 4 wheel steer
- Selectable front, crab & coordinated steering modes
- Auxillary hydraulic circuit on the boom
- Variable speed hydrostatic drive
- Fender (set of 4)
- Fully enclosed cab with air conditioning
- Proportional joystick controls
- Adjustable steering column
- Illuminated guage and switch panels
- Colour LCD display with machine & engine diagnostics
- Block heater
- Adjustable suspension seat
- Flashing beacon
- Road lights
- Fixed 1,200mm carriage
- 1,200mm x 1,500mm x 800mm pallet forks
- Work lights on boom (2)
- 2 year parts & labour, 5 year structural warranty
- CE approved

## OPTIONS

- Front and rear work LED lights

**snorkel** [www.snorkellifts.com](http://www.snorkellifts.com)

Vigo Centre, Birtley Road,  
Washington, Tyne & Wear,  
NE38 9DA, U.K.

t: +44 (0) 845 1550 057  
e: sales.emea@snorkellifts.com