

TL39

TOWABLE BOOM LIFT



- Tough yet compact trailer mounted boom lift
- Easy to set-up hydraulic outriggers
- Manoeuvrable articulating/telescopic boom
- Smooth, easy to operate controls
- Simple to maintain

 **snorkel**
www.snorkellifts.com

TOWABLE BOOM LIFT

TL39

DIMENSIONS	TL39
Max. working height	13.5m
Max. platform height	11.5m
Max. working outreach	6.4m
Platform width (C)	1.24m
Platform depth (D)	0.75m
Outrigger footprint (A x B)	4.0m x 3.6m
Towing width (E)	1.61m
Towing length (F)	5.0m
Stowed height (G)	2.01m

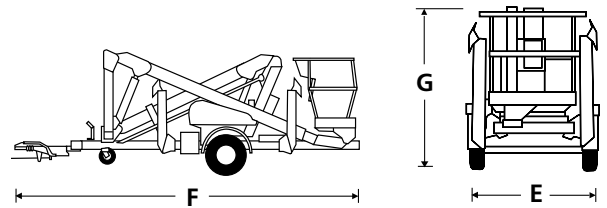
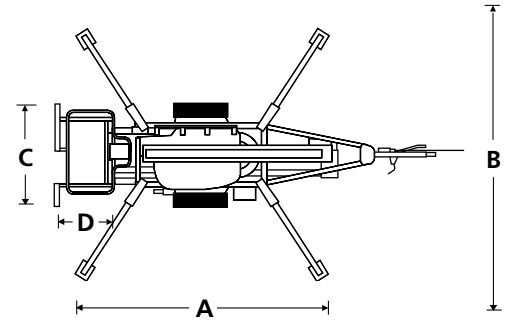

PERFORMANCE	
Platform capacity (SWL)	215kg
Max. wind speed	12.5m/s
Turret rotation (non-continuous)	540°
Tyres	185R14C
Controls	electric over hydraulic, variable speed

POWER	
Power source	24V battery (4 x 6V 226Ah batteries)
Power options	gasoline, bi-energy (combustion and battery), 24V DC electric, diesel

WEIGHT	
Weight (gasoline model)	1,480kg

STANDARD FEATURES

- Articulating / telescopic boom configuration
- Hydraulic outriggers
- Electric controls at platform
- Power line to platform
- Integral road lighting board
- Integrated automatic battery charger 110V-230V
- 2 year parts & labour, 5 year structural warranty
- CE approved

OPTIONS

- Special paint colours
- Auto-level outriggers with LED indicators
- Work lights in platform
- Airline to platform
- Flashing amber light
- Nylon spreader pads (set of 4)
- Environmental hydraulic oil

WORKING ENVELOPE

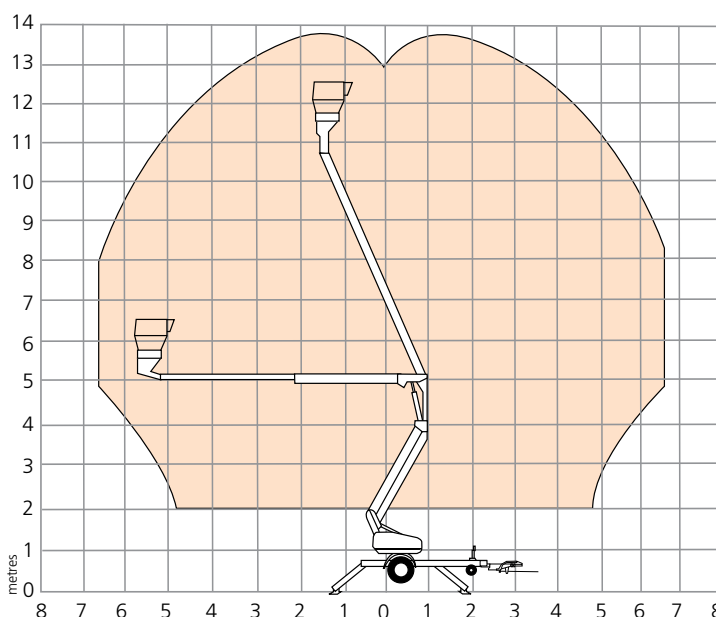

snorkel www.snorkellifts.com

Vigo Centre, Birtley Road,
Washington, Tyne & Wear,
NE38 9DA, U.K.

t: +44 (0) 845 1550 057
e: sales.emea@snorkellifts.com